



# INSTALLATION, OPERATION, MAINTENANCE & TROUBLESHOOTING OF EJECTOR SYSTEMS

BULLETIN # PVS-80025121-ESM

PAGE 1 OF 18

Founded in 1973 as a precision machine shop manufacturing close-tolerance steam turbine & compressor parts, Unique Systems soon began manufacturing ejector vacuum system components & assemblies for our largest customer, the Elliott Company, an industry leader in Turbomachinery & vacuum technology.

In 1985 we acquired the Elliott® vacuum equipment product lines, including ejectors, condensers, deaerating feedwater heaters, scrub coolers, grease extractors and other ancillary products. We have over 100 years of accumulated knowledge and expertise in process vacuum applications. Our files contain engineering & test data, technical & design specifications, microfilm & original mechanical drawings for all former Elliott vacuum equipment.

Since our acquisition of these product lines, Unique Systems has dedicated a considerable amount of resources to improving the already exceptional designs. As a result of these efforts, we proudly introduced our Quickcheck® Ejector Steam Chest which received both domestic & foreign patents and remains one of our best-selling products. We are also a proud member of the Heat Exchange Institute (HEI). All our equipment is designed and constructed in full compliance with HEI, ANSI, ASME, ASTM, TEMA and other domestic & international codes and standards, as applicable.

This technical document should be of immense assistance to both the professional engineer and end-user alike. It was written by Victor Fondrk, an authority on Ejector Vacuum Systems and related equipment, who devoted his entire professional career to the design, development and application of Ejector Vacuum Systems. He successfully designed the first ejector for absolute pressures under 10 microns and was responsible for many of our innovative ejector system installations worldwide. It explains immediate remedies for on-the-spot repairs while orders for replacement parts can be processed. Also of interest is the paragraph on how to upgrade your present system in order to conserve energy, a major concern to all ejector users. We believe you will find this information to be of great value!

Our expertise, large & diversified inventory, along with our competitive pricing policy, is your assurance of prompt service and quality parts at the lowest cost. Our staff considers it a privilege to service our customers; and, your inquiries & orders will always receive our prompt attention.

Respectfully yours,

Olof A. Eriksen  
 President

TOPIC	PAGE
<b>STEAM JET EJECTORS</b>	
Operating Principles	2
Single & Multi-Stage Ejectors	2
<b>INSTALLATION</b>	
Preliminary Inspection	3
Hydrostatic Test	4
Steam Strainer	4
Absolute Pressure Measurements	4
Shut-off Valve	4
Drain Lines	4
Steam Gauge	5
Wet Steam	5
Intercondensers	5
Aftercondensers	5
Discharged Steam	6
Discharge to Atmosphere or a Hotwell?	6
<b>OPERATION</b>	
Start-up	6
Shutdown	7
<b>FIELD CHECKING OF EJECTORS</b>	
Low Steam Pressure	7
Wet Steam	7
Superheat Steam	8
<b>ABSOLUTE PRESSURE MEASUREMENTS</b>	
Low Vacuum	8
Medium Vacuum	8
High Vacuum	9
<b>MAINTENANCE &amp; TROUBLESHOOTING</b>	
Preparation for Investigating an Ejector Problem	11
Preliminary Checks	11
System or Ejector?	12
Ejector Stage Inspection	14
Quickcheck Ejector Steam Chest	15
Inspection of Condensers	15
System Problems	16
Preventative Maintenance	16
Corrosion	17
Maintenance of Condensers	17
Energy Savings	17
"Wear in diffusers is more critical..."	18
<b>SUMMARY</b>	
	18

[www.uniquesystems.com](http://www.uniquesystems.com)

**The Unique "VIP" Service Advantage**

- Value, Integrity, Professionalism & Service •



# INSTALLATION, OPERATION, MAINTENANCE & TROUBLESHOOTING OF EJECTOR SYSTEMS

BULLETIN # PVS-80025121-ESM

PAGE 2 OF 18

## STEAM JET EJECTORS

### OPERATING PRINCIPLES

Steam jet ejectors operate on a mass-velocity principle. The propelling steam expands through a divergent nozzle, converting its pressure energy into velocity energy. The mass of high-velocity steam is discharged from the nozzle in a directed flow through an air chamber and into a convergent-divergent diffuser. As the steam passes through the air chamber it comes in contact with, and entrains, a definite mass of the vapors to be evacuated. It imparts to this mass a portion of its own velocity by being decelerated and the resultant total mass at the resulting velocity enters the diffuser where its velocity energy is, in the greater part, converted into pressure, thus permitting the mass to be discharged at a pressure considerably higher than the pressure in the air chamber. The entrained mass is thus compressed from a low absolute pressure to some higher absolute pressure.

### SINGLE- & MULTI-STAGE EJECTORS

When all of the desired compression is accomplished in a single diffuser, the unit is known as a single-stage ejector. A limited amount of compression may be accomplished more economically in a single-stage ejector than in a multi-stage unit.

As with other gas compression apparatus, energy may, in some cases, be saved by affecting compression in several stages. Where the vacuum is high, the discharge pressure high, or the steam pressure low, multi-stage compression is desirable.

In a multi-stage ejector, the total amount of compression which it is desired to accomplish is divided between two or more ejectors operated in series. The ejector which the entrained gases first enter is called the first stage and subsequent stages are numbered in succession. It is usually desirable to connect a small condenser to the discharge of each diffuser primarily for the purpose of reducing all condensable gases to the liquid state, thus imposing on subsequent stages the work of compressing only those gases that are non-condensable. The condensers so employed are known as intercondensers. A condenser connected to the diffuser discharge of the final stage is known as an aftercondenser. Inter- and aftercondensers may be either barometric (direct-contact) or shell & tube condensers.

A single-stage ejector requires no intercondenser, but an aftercondenser may be used, if desired.

A two-stage ejector usually has an intercondenser between stages, and an aftercondenser may also be employed. Where the capacity required is small, the steam consumption is not important or where space limitations will not permit installing an intercondenser, a two-stage ejector may be non-condensing with the discharge of the first stage connected to the suction of the second stage.

A three-stage ejector, except in unusual cases, employs two intercondensers. An aftercondenser may be used, if desired. For unusually high vacuum and small capacity, or where the temperature of the condensing water is relatively high, the intercondenser between the first and second stages of a three-stage ejector may be omitted and the discharge of the first stage connected directly to the suction of the second stage. For very small capacities, or where steam consumption is of little importance, both intercondensers may be omitted.

### **The Unique "VIP" Service Advantage**

- Value, Integrity, Professionalism & Service •



# INSTALLATION, OPERATION, MAINTENANCE & TROUBLESHOOTING OF EJECTOR SYSTEMS

A four-stage ejector is used for very high vacuum. It does not have an intercondenser between the first and second stages.

A five-stage ejector is used for extremely high vacuum. It does not have an intercondenser between the first and second stage or between the second and third stages.

An intercondenser operates at pressures less than atmospheric; or, in other words, under vacuum. It is therefore necessary to provide means for draining the mixture of condensing water and condensed steam from a barometric (direct-contact) intercondenser, or the condensed steam only from a shell & tube intercondenser.

An aftercondenser operates at atmospheric pressure and is provided with a vent to allow the air and non-condensable gases to escape. The aftercondenser does not improve the economy of an ejector and is used to recover the heat of the steam, to recover condensate, or to condense the steam from the final stage in order to prevent its being a nuisance.

## INSTALLATION

**Figure 1** is a schematic diagram which illustrates the recommendations in this section. The installation shown is for ejector stages with barometric (direct-contact) condensers. Shell & tube condensers are installed in a similar way, except the drain legs to the hotwell are for condensate and cooling water is returned to the cooling water system after passing through the condensers.

### PRELIMINARY INSPECTION

After unpacking the equipment, carefully inspect all openings to make sure that no foreign material has been left inside; and, ensure that all bracing, blocking, opening covers or wooden plugs used to protect the equipment during shipment have been removed. Before installing the ejector, check all flange bolts of the ejector and tighten as necessary. Gasket shrinkage and vibration during transit may cause bolts to loosen. If the ejector is placed in operation before tightening the flange bolts, air leakage through the gaskets may cause the ejector to operate unsatisfactorily or the steam chest gasket may blow out.

**FIGURE 1: TYPICAL INSTALLATION OF THREE-STAGE BOOSTER EJECTOR**

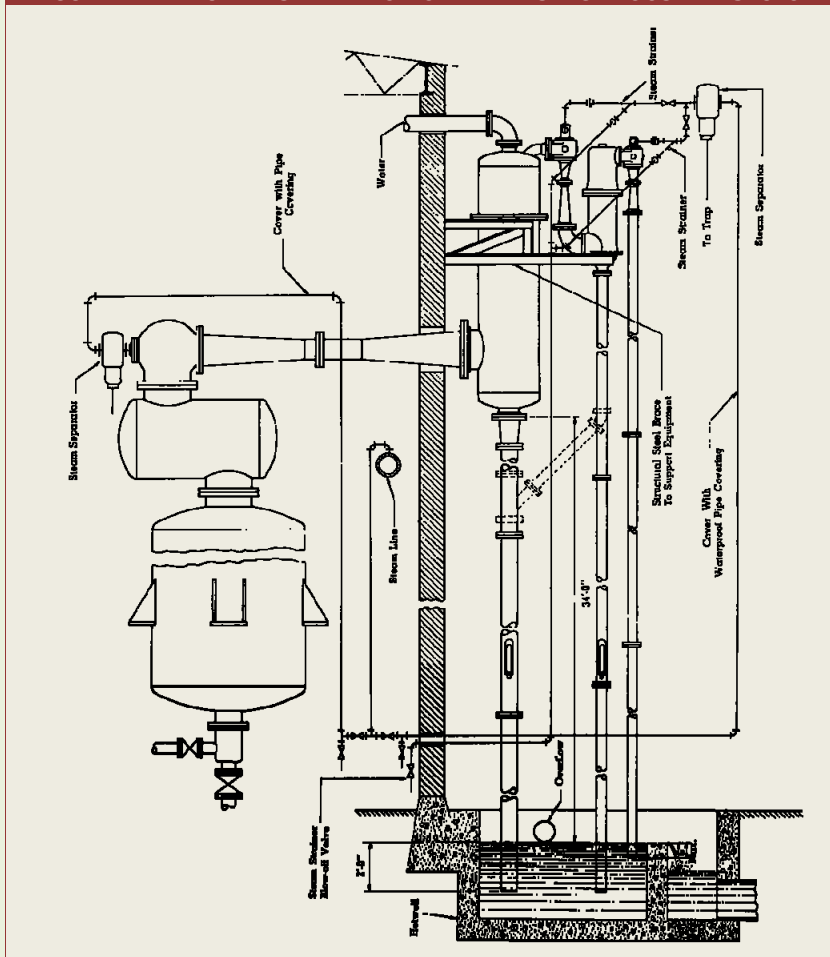

### The Unique "VIP" Service Advantage

- Value, Integrity, Professionalism & Service •



# INSTALLATION, OPERATION, MAINTENANCE & TROUBLESHOOTING OF EJECTOR SYSTEMS

## HYDROSTATIC TEST

In order to be sure that the system which the ejector system serves is airtight, apply a hydrostatic test to all parts of the system and piping subject to vacuum. It is important that the system is airtight. Air leaks can be located by filling the system with water and noting where the water leaks out. The fittings holding gauge glasses, pipe threads into flanges, and any unions in the pipe lines under vacuum, in particular, should be carefully inspected. Any leaks discovered should be eliminated.

## STEAM STRAINER

When nozzle throat diameters are less than 3/8", install a steam strainer in the steam line as close to the ejector steam inlet connection as possible and provide the strainer with a blow-off valve.

Self-cleaning steam strainers with removable baskets extract dirt, grit, scale or any other foreign matter from the operating steam and thus prevent this foreign matter from clogging the nozzles of the ejector. These strainers can be installed in either horizontal or vertical pipe lines and are provided with a basket having .020" diameter perforations. The total area of the perforations is several times the inlet or outlet area of the strainer. These strainers should be installed with a blow-off valve, which may be connected to a drain line, if desired. The strainer is cleaned by simply opening the blow-off valve. Before starting the ejector, the blow-off valve should be opened for a minute or so in order to clean the strainer and relieve the steam line of any condensation that may have collected. The blow-off valve may be closed as soon as the steam discharged is free from small drops of water. Cleaning the strainer at regular intervals during operation of the ejector is recommended. The strainer basket should be removed every six months or so and inspected to make sure it is in good condition and has not been burst by excessive accumulation of foreign matter.

## ABSOLUTE PRESSURE MEASUREMENTS (See also Page 8)

The air chamber of each ejector is typically provided with a tapped opening for a manometer connection. Ejectors are guaranteed in terms of inches or millimeters of mercury absolute pressure. To measure the absolute pressure maintained by the ejector, connect a manometer to the suction chamber by a short length of vacuum grade rubber hose. Provisions should be made for bleeding moisture from the line by sloping it to drain toward the ejector. It is also advisable to install a vacuum-tight valve in a tee at the vacuum-side of the manometer. To remove moisture, with the ejector in operation, open the valve to atmosphere and momentarily bleed air through the gauge line. All manometer readings should be referred to a barometer corrected for temperature and elevation. Barometric pressure may vary an inch or more due to weather conditions and barometric pressure decreases approximately one inch per 1,000 feet of elevation above sea level. It is therefore apparent that a vacuum reading must be referred to a true barometer to have any significance.

## SHUT-OFF VALVE

A vacuum tight shutoff valve should be installed in the vacuum line ahead of the ejector. Closing the valve permits checking the shut-off pressure of the ejector and facilitates shutting down the ejector.

## DRAIN LINES

Install a drain line with a good vacuum-tight valve at every low point in the vacuum line and in the ejector so that any water pocketed in these low points when the ejector is shut down can be drained before starting up the ejector.

### **The Unique "VIP" Service Advantage**

- Value, Integrity, Professionalism & Service •



# INSTALLATION, OPERATION, MAINTENANCE & TROUBLESHOOTING OF EJECTOR SYSTEMS

BULLETIN # PVS-80025121-ESM

PAGE 5 OF 18

## STEAM GAUGE

Each ejector steam chest is typically provided with a tapped opening for a gauge connection which is plugged before shipment to prevent the entrance of any foreign matter. An accurate and dependable steam gauge should be installed on the ejector steam chest, or on the steam line close to the ejector, and the steam pressure kept exactly at or slightly above the steam pressure for which the ejector is designed. The design steam pressure is always stamped on the nameplate affixed to the ejector. It is important that the steam gauge be accurately calibrated before it is installed and checked at regular intervals. Steam pressure gauges provided with check screw and socket with slotted link to take care of sudden pressure release are recommended.

## WET STEAM (See also Page 7)

As wet steam seriously affects the efficiency of ejectors, a steam separator should be installed in the steam line close to the ejector to insure dry steam. The steam supply for the ejector should be taken from the top of the main steam header. All steam lines and the steam chests of the ejector stages should be well insulated with a good grade of pipe covering.

## INTERCONDENSERS

Barometric (direct-contact) condensers should be installed with a shut-off and control valve in the cooling water line to each condenser. A thermometer should be provided to measure temperature of cooling water to the condensers and a thermometer located in the drain line from each condenser. The thermometers are used to set the required temperature rise across each condenser. Cooling water to condensers may be series or parallel flow, depending upon design. If it is parallel, flow valves are required to control water quantity to each condenser. If water is series flow, only a single control valve is required. In either case, inlet water temperature measurement should be provided, as well as discharge temperature from each condenser.

Separate tail pipes should be provided for each intercondenser. Use of barometric legs is a simple and safe arrangement for draining condensers. It is also possible to drain condensers in a condensate receiver equipped with a level controller and pump. This eliminates the height associated with a barometric leg but introduces the hazard of flooding the vacuum system if either pump or controller fails.

## AFTERCONDENSERS

The mixture of condensing water and condensed steam from a barometric (direct-contact) aftercondenser, or the condensed steam only from a shell & tube aftercondenser, can be drained by gravity. Since the air discharged from the air vent of an aftercondenser is highly saturated and is at a relatively high temperature, usually some of the water vapor of saturation is condensed out when this air is discharged into a room at normal temperature, giving it the appearance of steam. For this reason, if desired, the air vent from the aftercondenser can be piped to atmosphere at some point where the saturated air and non-condensable gases discharged from the vent will not be objectionable. If a valve is installed in an air vent line from a shell & tube aftercondenser, it is very important that the ejector never be started up unless this valve is wide open. If the air vent is closed and the ejector started, the entire system may eventually be subjected to operating steam pressure, which it may not be designed to withstand.

### **The Unique "VIP" Service Advantage**

- Value, Integrity, Professionalism & Service •



# INSTALLATION, OPERATION, MAINTENANCE & TROUBLESHOOTING OF EJECTOR SYSTEMS

BULLETIN # PVS-80025121-ESM

PAGE 6 OF 18

## DISCHARGED STEAM

The steam used by single-stage ejectors, or by the last stage of multi-stage ejectors, can be discharged directly to atmosphere, to a hotwell or to an aftercondenser. However, extreme care should be taken to make sure that the ejector does not discharge against a higher pressure than that for which it is designed.

## DISCHARGE TO ATMOSPHERE OR A HOTWELL?

Where the steam from the ejector is discharged to atmosphere, if an exhaust steam line is used, it should be short and with as few fittings as possible so as to have as little friction and as low a discharge pressure as possible. If the exhaust steam line is relatively short and has few fittings it can be the same size as the discharge opening on the ejector; but, if it is very long or has several fittings, it should be one size larger than the ejector discharge opening. Some of the steam discharged from the ejector will condense in the exhaust steam line; therefore, all exhaust lines should be arranged to drain freely. A horizontal run should slope towards the discharge and any place where condensate can pocket should be provided with a drain. For example, a horizontal run from the ejector should connect to a vertical upward run by a tee (not an elbow) with a drain line connected to the bottom opening of the tee, which should be protected against freezing.

Where the steam from the ejector is discharged into a hotwell, the discharge line should not be submerged more than 12" and preferably not more than 6-8". If the difference in elevation between the ejector discharge and the hotwell water level is less than 34 feet, the discharge line should have a check valve in it. Submerging the discharge line 6-8" in the hotwell has the advantage of being self-sealing. If the volume of water in the hotwell between the normal level and the lower end of the discharge line is sufficient to fill the exhaust line for 34 feet, the system will not lose vacuum instantly if the ejector is accidentally shut off.

## OPERATION

### START-UP

Before starting ejector system, all liquid should be drained from the vacuum-side by opening valves in installed drains. Steam lines should be blown down to remove condensate and to heat the steam lines. The start-up sequence is:

- A) Open water flow to aftercondenser, if any.
- B) Open steam to last stage ejector (atmospheric discharge).  
Evacuate system to about 4-8" Hg Abs. using last stage only.
- C) Open water flow to condenser located between the last stage and next-to-last stage.
- D) Open steam to ejector stage that precedes last stage.
- E) Repeat C & D until all stages are on.

The above sequence will provide the fastest pump-down time and minimize backflow of steam into the system.

### The Unique "VIP" Service Advantage

- Value, Integrity, Professionalism & Service •



# INSTALLATION, OPERATION, MAINTENANCE & TROUBLESHOOTING OF EJECTOR SYSTEMS

BULLETIN # PVS-80025121-ESM

PAGE 7 OF 18

## SHUTDOWN

To shut down ejector system, reverse the start-up procedure. The first stage is shut down, then the second, etc., with the last (atmospheric) stage being the final stage to be turned off. If last stage discharges to atmosphere, vacuum will be broken by air being drawn through the ejector stages. If last stage discharges into the hotwell below water level, vacuum equivalent to the vapor pressure of cooling water will be maintained after stages are shut down. In either case, the system being served should be isolated with a valve at first stage suction.

## FIELD CHECKING OF EJECTORS

### LOW STEAM PRESSURE

A frequent cause of unsatisfactory ejector operation is low steam pressure. This sometimes goes unrecognized due to faulty gauging. To check steam pressure, a calibrated gauge should be installed as close to the ejector as is feasible – preferably right at the steam chest. Any fittings or length of line between pressure gauge and ejector will cause pressure drop, and the steam pressure felt by the ejector will be lower than that read by the gauge.

### WET STEAM (See also Page 5)

Ejector performance is materially affected by the condition of the steam it receives. Wet steam is always undesirable because it may cause ejector vacuum to break or fluctuate. Even if this condition is not serious, or objectionable, wet steam will shorten the life of the ejector, eroding diffusers so that they must be replaced.

One check on the conditions of steam is a thermometer in a well, close to the ejector stage being tested. Interpretation of results is by no means clear-cut. If the thermometer reads saturation temperature, or even some superheat, there is a good possibility of moisture in the steam. It must be remembered that steam table values are measured at equilibrium condition. It is possible for a superheated steam stream to pick up water from stagnant pockets in the line and flow for some distance without reaching equilibrium. This is more probably during start-up or in the case of intermittent service.

One way to check qualitatively is to open a steam bleed and watch the jet. Highly superheated steam is completely invisible for some distance beyond the bleed. Steam close to saturation temperature becomes visible a short distance from the opening as a blue jet changing to white. Slugs of water in a saturated or superheated stream are visible as periodic puffs of white. A white jet shows high moisture content.

It should be stressed that temperature as well as pressure measurements are made as close as possible to the stage in question. To illustrate the importance of this point, it has been observed that in a multi-stage ejector having a common steam supply manifold, the temperature of steam to each stage may be considerably different. This is due partly to different length of line and fittings from manifold to ejector, but mainly to the fact that the steam consumption of one stage may be a small fraction of the following stage. Since heat loss from a line is mainly from radiation, the BTU loss per pound is more serious for low steam flows. If use of a steam bleed helps the performance of the ejector, wet steam is certainly present.

All low points in steam piping should be trapped to remove condensed steam.

### The Unique "VIP" Service Advantage

- Value, Integrity, Professionalism & Service •



# INSTALLATION, OPERATION, MAINTENANCE & TROUBLESHOOTING OF EJECTOR SYSTEMS

BULLETIN # PVS-80025121-ESM

PAGE 8 OF 18

## SUPERHEAT STEAM

The most important observable improvement in ejector performance due to superheat is the elimination of wet steam difficulties. Excessive superheat may be a source of trouble if the ejector is not designed for it. An ejector is designed to use a certain weight of steam to handle a given weight of gas or vapor. Superheat higher than design condition cuts down the weight rate of steam flow through the ejector nozzle. As an example, let's cite a single-stage ejector working against a 29" barometer, designed for 31" back pressure, with 100 PSIG dry & saturated steam. Using the HEI method of computing steam flow, it can be shown that with about 171°F superheat, the ejector will be close to, if not actually, breaking provided steam pressure is not raised to compensate for decreased steam flow.

## ABSOLUTE PRESSURE MEASUREMENTS (See also Page 4)

The following is presented as a basic overview of Absolute Pressure Measurements. Detailed information and instructions are available in any good vacuum text or from HEI Standards.

### LOW VACUUM

For a single-stage ejector, relatively crude instruments will often suffice. In an emergency it is always possible to construct a manometer from a piece of bent glass tubing and a yard stick, or even a straight glass tube and a bottle. Even where only approximate readings are desired, vacuum gauges are not recommended. If such a gauge must be used, it should be frequently checked against manometer readings.

For measuring vacuum in first of two stages, a more refined manometer is recommended. Such a manometer is available with a vernier scale reading to 1/100-inch. The tubing is wide bore to virtually eliminate capillary effects. For accurate manometer readings it is necessary to make a zero correction, refer readings to a barometer reading corrected for temperature and elevation, and check manometer for leakage.

The test for leakage is made simply by pulling vacuum on the manometer and clamping off the hose back at the ejector. If vacuum drops more than one- or two-tenths of an inch of mercury per minute, leakage should be stopped. All joints between ejector and manometer glass are under suspicion. Sometimes the hose itself is at fault due to age, hard use or porosity. Long lengths of gauge line are to be avoided.

A breaking ejector will often throw water back to the gauge lines. To remove water, disconnect the hose at the manometer and blow the line clear by admitting air through the hose to the ejector.

### MEDIUM VACUUM

The simplest instrument for the range 0.5–15 mm mercury absolute is an oil manometer using di-n-butyl phthalate as a fluid. The reference arm of this instrument should be connected to a high vacuum and McLeod gauge.

Some precaution must be observed. The tubing must be at least ¼" I.D. bore. Gauge fluid and glass must be completely free of dirt and impurities. The entire system must be degassed for some time before using. Very careful checks for leakage must be made in a similar manner to that previously described.

### **The Unique "VIP" Service Advantage**

- Value, Integrity, Professionalism & Service •





## INSTALLATION, OPERATION, MAINTENANCE & TROUBLESHOOTING OF EJECTOR SYSTEMS

### HIGH VACUUM

High vacuum measurements are difficult due to the extreme care that must be taken to avoid leakage and any internal source of error. For example, the use of stopcock grease having high vapor pressure. For detailed information concerning joints, etc., refer to any good vacuum text.

The other difficulty is the lack of a simple direct reading absolute gauge. For most high vacuum work, the McLeod gauge with cold trap is the primary standard. A McLeod gauge depends on Boyle's Law, which states that with temperature constant, the volume of gas is inversely proportional to its pressure. A sample of gas is trapped in the gauge and compressed many times to a small calibrated volume by the pressure of a column of mercury. The great difficulty with this gauge is that if any vapor is present in the sample, it will be condensed as it compresses, and the McLeod will read a partial pressure somewhat lower than the true absolute pressure. This error may sometimes be corrected by installing some sort of cold trap ahead of the gauge to freeze out any vapor.

There are several types of high-quality electronic gauges, which can be purchased and used instead of a manometer or McLeod gauge; however, McLeod gauges continue to be used as a calibration standard for electronic gauges.

### MAINTENANCE & TROUBLESHOOTING IMPROVE EJECTOR PERFORMANCE THRU PROPER MAINTENANCE

Steam ejectors are simple vacuum producing devices that operate without moving parts and usually give many years of trouble-free operation. Most users accept this characteristic without thought and infrequently concern themselves with maintenance or measurement of actual performance against design. However, problems do occur occasionally. This section will present a systematic method of determining causes of poor performance; and, it will outline corrective measures once the cause has been found and isolated. Also covered will be suggestions for preventative maintenance and methods to improve and save energy on new and/or existing systems.

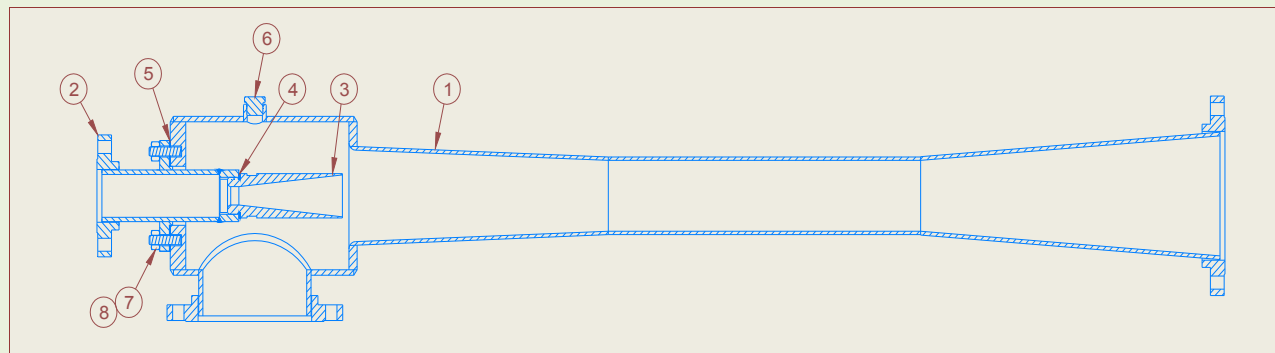

**FIGURE 2: CROSS-SECTION OF TYPICAL TYPE "E" STEAM JET EJECTOR**

- |  |                                     |
|--|-------------------------------------|
| 1 Suction Chamber & Diffuser (Body Weldment) | 5 Gasket, Steam Chest               |
| 2 Motive Steam Chest                         | 6 Vacuum Gauge Connection (Plugged) |
| 3 Steam Nozzle                               | 7 Threaded Stud                     |
| 4 Nozzle Spacer                              | 8 Heavy Hex Nut                     |

**Figure 2** is a cross-section of a typical single-stage ejector. **Figure 3** is a cross-section of a typical two-stage ejector with a barometric (direct-contact) intercondenser. **Figure 4** is a cross-section of a typical two-stage ejector with shell & tube intercondenser. The nomenclature shown on these figures will be used in this section.

### The Unique "VIP" Service Advantage

- Value, Integrity, Professionalism & Service •



# INSTALLATION, OPERATION, MAINTENANCE & TROUBLESHOOTING OF EJECTOR SYSTEMS

**FIGURE 3: CROSS-SECTION OF TYPICAL TYPE "B" STEAM JET EJECTOR**

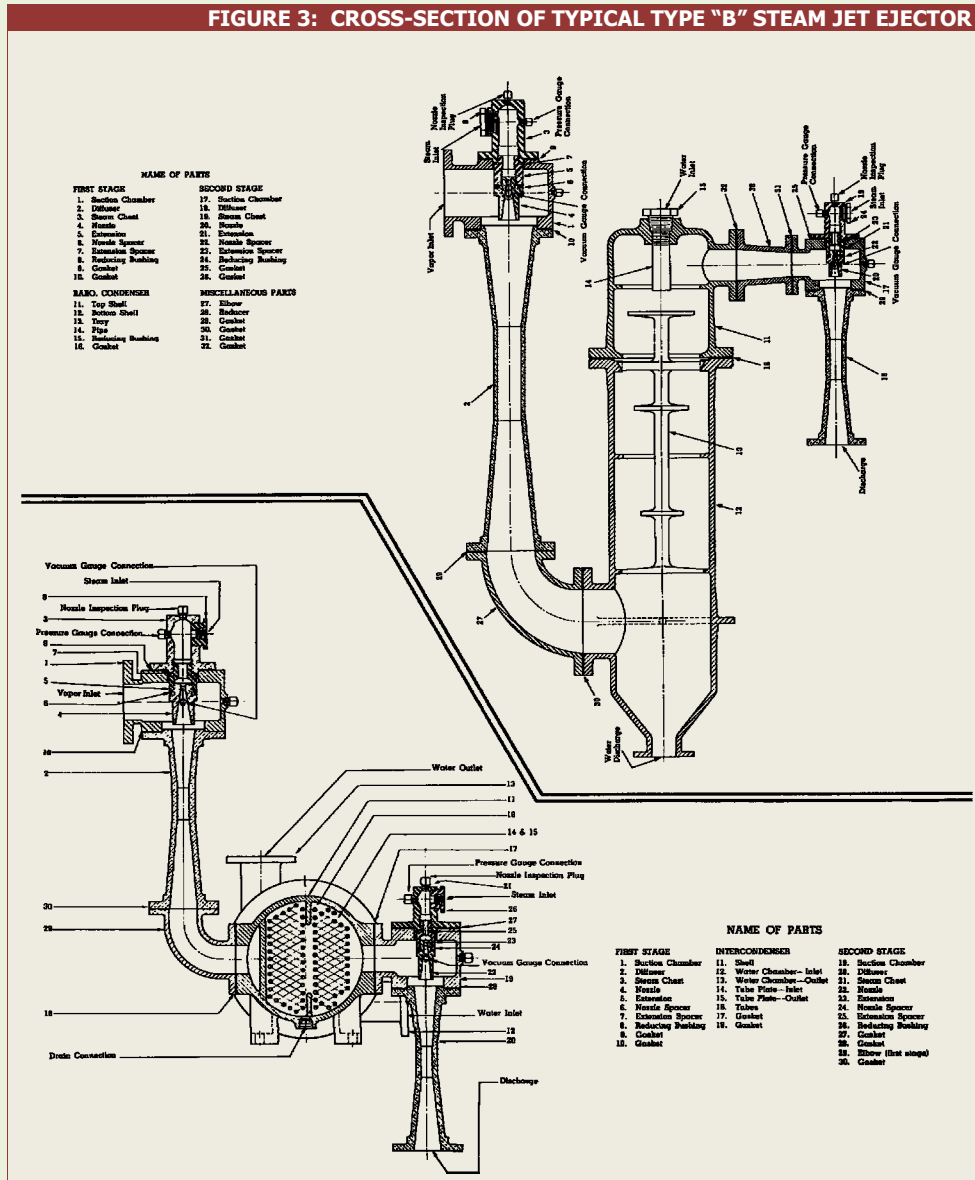

**FIGURE 4: CROSS-SECTION OF TYPICAL TYPE "C" STEAM JET EJECTOR**

To avoid the ambiguity caused by use of the term "vacuum" in referring to pressure levels in a vacuum system, this section will use Torr for pressures associated with the vacuum side of the ejector system. Torr is the absolute pressure in millimeters of mercury. Standard atmospheric pressure is 760 Torr and 25.4 Torr equals 1" of mercury absolute.

**The Unique "VIP" Service Advantage**

- Value, Integrity, Professionalism & Service •



# INSTALLATION, OPERATION, MAINTENANCE & TROUBLESHOOTING OF EJECTOR SYSTEMS

BULLETIN # PVS-80025121-ESM

PAGE 11 OF 18

## PREPARATION FOR INVESTIGATING AN EJECTOR PROBLEM

When preparing to investigate an ejector problem, it is important to have available as much design data for the ejector system as possible. The following are generally available from the instruction book for the unit or from the original purchase specification:

1. Minimum steam pressure.
2. Maximum operating steam temperature.
3. Maximum water inlet temperature.
4. Water outlet temperature for each condenser.
5. Absolute pressure (vacuum) to be maintained by the ejector.
6. Amount of load to be handled by the ejector while maintaining design vapor inlet pressure.
7. Maximum discharge pressure for the last ejector stage.

Other essential design data is usually available from the ejector manufacturer and includes:

1. Diffuser throat diameter for each stage.
2. Steam nozzle throat diameter for each stage.
3. Design inter-stage pressure for multi-stage systems.
4. Performance curves of the unit and the last stage of a multi-stage ejector.

Also needed, will be calibrated instruments to accurately measure steam pressures, steam temperature, water temperature and the various pressure levels at different points on the vacuum-side of the ejector system. For vacuum measurements it is advisable to avoid use of spring-type gauges as these are seldom accurate enough for diagnostic work. Mercury or oil manometers will give more accurate readings. Reference should be made to HEI "Standards for Steam Jet Ejectors" for a description of techniques for measuring absolute pressures in ejector systems. See also section entitled **ABSOLUTE PRESSURE MEASUREMENTS** on Page 8.

## PRELIMINARY CHECKS

Before extensive investigation is undertaken, some simple observations should be made to see if there is an obvious reason for a change in performance. Answers to the following questions should be determined:

### **1. Has there been a process change that has increased or decreased the composition of the load to the ejector?**

If there has been a significant change, then the estimated new loads should be given to the ejector manufacturer for evaluation and recommendations on equipment changes required to accommodate the new loads.

### **2. Has there been a change in plant steam conditions?**

Additional equipment using steam, and added to the line(s) serving the ejector, may have altered steam conditions to the ejector. Steam pressure and temperature should be accurately measured at the ejector steam chests to insure that the steam pressure is at or above minimum and steam temperature is less than the maximum. If conditions have changed, new nozzles should be purchased for the new conditions.

### **3. Has water supply temperature increased over time and now exceeds design**

#### **The Unique "VIP" Service Advantage**

- Value, Integrity, Professionalism & Service •



# INSTALLATION, OPERATION, MAINTENANCE & TROUBLESHOOTING OF EJECTOR SYSTEMS

BULLETIN # PVS-80025121-ESM

PAGE 12 OF 18

## maximum temperature?

If temperature now exceeds design, the new condition should be given to the ejector manufacturer for evaluation. Minor equipment changes and only a nominal increase in steam and water usage usually can accommodate small increases in temperature.

## 4. Has the discharge pressure of the last stage increased?

This could be the result of changes in discharge piping or blockage due to dirt or corrosion. Pressure should be measured as close as practical to the discharge end of the stage and compared with specified maximum value. If there has been a change, the manufacturer can supply a new nozzle for the last stage to operate against the higher discharge pressure.

## SYSTEM OR EJECTOR?

If preliminary observations shed no light on the problem, the next step is to determine if the problem is the system being served or the ejector.

It is difficult to test an ejector when it is connected to the system being served. Air leakage, leaking steam valves connected to the system, and pockets of volatile liquids lying in the system could impose an indeterminate load on the ejector.

A more meaningful test is obtained if the system is isolated from the ejector. This is done by installing a blind flange as close as practical to the vapor inlet of the first stage. The blind flange must be mechanically suitable for a differential pressure of 15 PSI. A valve near the first stage vapor inlet can also be used to isolate the ejector if it is known that the valve is leak free when in the closed position. This is not always the case, and it is better to install a blind flange if there is any doubt.

Once the ejector is isolated it should be instrumented with pressure and temperature gauges and placed in operation. Steam pressure should be adjusted to minimum design pressure and temperature should not exceed specified maximum. Where condensers are a part of the ejector system, water flow to each condenser should be set at design valves by adjusting flow to give specified temperature difference between inlet and outlet water temperatures. Inlet water temperatures should not exceed maximum design value. Discharge pressure at the last stage should be measured to make certain that it is less than design.

If the ejector being checked is a single-stage unit and the reading on the vacuum gauge shows an absolute pressure appreciably lower than it did when connected to the system, and if this pressure is not fluctuating, it can be assumed that the ejector is operating satisfactorily and the problem is in the system. Most single-stage designs will pull down well under 80 Torr against a blanked-off vapor inlet.

If the pressure at the vapor inlet of a single-stage ejector pulls down to a low absolute pressure and then "breaks" to higher pressure, and continues a cycle of unstable operation against a blanked off vapor inlet, the problem may be a worn diffuser. However, many single-stage ejectors are not designed for stability at no load, so additional testing is necessary to determine if the unstable operation is inherent in the design or if it is actually a worn diffuser. This can be determined in one of two ways. If there is sufficient pressure available to raise steam pressure by 10% above the design minimum, the ejector should become stable at no load. If it does, the likelihood is that the ejector is in reasonably good

### **The Unique "VIP" Service Advantage**

- Value, Integrity, Professionalism & Service •



UNIQUE SYSTEMS®

INCORPORATED

ONE SADDLE ROAD - CEDAR KNOLLS, NEW JERSEY 07927-1998

Phone 973-455-0440 Fax 973-455-7214



## INSTALLATION, OPERATION, MAINTENANCE & TROUBLESHOOTING OF EJECTOR SYSTEMS

BULLETIN # PVS-80025121-ESM

PAGE 13 OF 18

condition. If additional steam pressure is not available, introduce a small load into the vapor inlet. A load equal to 15% of design capacity should give stable operation with design steam pressure. This amount of load can be introduced into the vapor inlet through a small hole drilled in the blind flange or drilled into a pipe plug located in the vapor inlet line between shut-off point and the ejector. The required size of the hole can be calculated by multiplying the 70°F air equivalent design capacity in pounds per hour by 0.15 and dividing by 900. The result is in area of the hole in square inches. After drilling the hole it should be deburred and the entrance generously rounded and blended with the hole diameter. If the ejector operates stably with the introduced load, it can be assumed that the stage is in reasonably good condition.

If the higher steam pressure or air introduced through the drilled hole results in an absolute pressure considerably better than obtained when operating on the system, it can be assumed that the ejector is in relatively good condition and the problem is in the system.

If the ejector being checked is a multi-stage unit and it pulls down to an absolute pressure considerably better than when operating on the system, there is a strong likelihood that the ejector is in satisfactory condition and the problem again is in the system. A multi-stage ejector should produce a no load absolute pressure of less than 20% of the design pressure, and this pressure should be stable. Under no load conditions, the last stage may be unstable if a condenser precedes it, but this instability should not be great enough to cause unstable operation of the first stage. Regardless, an unstable last stage can be stabilized as described above for single-stage units.

Where one or more condensers are used in a multi-stage ejector system, further testing may be necessary even if the no load test is satisfactory. If the design load for the unit is entirely non-condensable, the air equivalent of this load should be introduced into the first stage vapor inlet using a drilled hole, as described above, for single-stage units.

**Note:** If design load included non-condensable gases whose average molecular weight is different from air, more sophisticated methods of loading the ejector will be necessary. HEI Standards contain methods for calculating test loads when the non-condensable design load has a molecular weight different from air.

If the ejector maintains design pressure under the load imposed by the drilled hole, it can be assumed that the condition of the ejector is satisfactory. If pressure at the vapor inlet of the first stage is higher than design, or unstable, measurement of the vapor inlet pressure on stages following intercondensers should be made and compared with design values. Higher-than-design pressures are indications of malfunction of the intercondenser or of that stage. Further checking of the stages which show abnormal pressure levels can be made by isolating these stages and conducting the tests described above. In isolating parts of the ejector unit for further testing, the procedure is to start by blanking off the last stage for testing and then successively blanking off preceding stages until the defective stage or condenser is located.

If design load for the unit is a mixture of air and steam, it is impractical for a field test to load the unit with both air and steam. If the unit is a single-stage ejector or a multi-stage unit without condensers, the air equivalent of the air-steam mixture can be used as a test load. The procedure for calculating the air equivalent for an air-steam mixture is given in HEI Standards. For multi-stage units with condensers, the air component only of the design load should be used to load the unit for testing. While not a complete test, this partial loading should give a good indication of any abnormality within the ejector unit.

### **The Unique "VIP" Service Advantage**

- Value, Integrity, Professionalism & Service •



# INSTALLATION, OPERATION, MAINTENANCE & TROUBLESHOOTING OF EJECTOR SYSTEMS

BULLETIN # PVS-80025121-ESM

PAGE 14 OF 18

## EJECTOR STAGE INSPECTION

If the results of the testing indicate one or more stages are not performing satisfactorily, these stages should be removed and dismantled for inspection. The purpose of inspection is to check for corrosion, erosion or build-up of foreign deposits in nozzles and diffusers. While ejectors generally give long, trouble-free service, they will eventually erode, particularly if operated with wet steam. Similar problems will occur if the unit is being operated in a corrosive atmosphere, and the combination of erosion and corrosion can cause rapid deterioration. Inspection should focus on the following areas:

- 1) Diffuser** – Check for build-up on the inside surfaces of the diffuser and clean these out with a scraper and abrasive cloth. If there are signs of pitting or grooving, these should be smoothed and blended to give a uniform and clean surface. Caution: Excessive metal removal from nozzle & diffuser must be avoided at all costs.

After cleaning, measurements should be taken of the diameter of the straight section of the diffuser – the diffuser throat. Measurements should be taken at several locations along the length of the throat and in several radial planes. If there is significant out-of-roundness or taper along the length of the throat, or if pitting and grooving cannot be corrected without excessive removal of metal, the diffuser should be replaced.

In theory, an increase in the diffuser throat diameter will cause failure of that stage. In practice, however, units are designed with some margin and an increase of 1% or 2% of the original diameter may not cause a problem. If wear is greater than this, and replacement is not available, operation of the stage may be temporarily restored by increasing steam pressure or re-boring the steam nozzle to a larger diameter. The steam pressure or steam nozzle area should be increased by 1.25 times the percentage wear in the diffuser throat area. As an example, if the diffuser throat diameter has increased 3% due to wear, its area has increased by 6.1%. To compensate, steam pressure should be increased by  $1.25 \times 6.1 = 7.63\%$  or the steam nozzle area increased by this amount. If the diffuser is badly pitted or grooved, the steam pressure or nozzle area may be increased more than the 1.25 factor with actual amount determined by trial-and-error. The temporary fix will cause increased usage of steam, so replacement parts should be obtained as soon as possible.

- 2) Nozzle** – Nozzles also may wear or corrode, but usually not to the extent of diffusers, which is due to the industry practice of using stainless steel for this component of the ejector. Even if wear does occur, the only apparent effect is increased steam consumption. In fact, wear in the nozzle can be beneficial if it compensates for wear in the diffuser. However, there is a limitation of the amount of wear that can be tolerated because ***increased steam flow through the nozzle will decrease capacity of the stage.***

Corrosion on the outside of the nozzle may also occur if gases being handled are corrosive. The impact on the outside of the steam nozzle as these gases enter the suction chamber may corrode the relatively thin end of the nozzle, thereby distorting steam flow from the nozzle enough to affect performance. Length of nozzle should be checked against original dimension and the nozzle should be replaced if there is an indication that the end of it has worn away. Also, if boiler scale has built up on the inside of the nozzle, performance will be affected. It is usually easy to remove this scale, which should be done before reassembly of the unit.

A frequent problem associated with steam nozzles is a steam leak through the threads on the nozzle. A small steam leak usually leaves a white or light tan streak on adjoining surfaces and will soon cut a groove due to steam wire drawing through the leak. If parts are not immediately available, a temporary fix may be made by facing off any grooved surfaces and compensating for the decreased length with a thicker nozzle washer or gasket.

### **The Unique "VIP" Service Advantage**

- Value, Integrity, Professionalism & Service •



# INSTALLATION, OPERATION, MAINTENANCE & TROUBLESHOOTING OF EJECTOR SYSTEMS

If a nozzle is to be re-bored to a larger diameter, it will be necessary to re-machine the inlet to produce a rounded entrance that blends into the new diameter and reduces the length of the new throat. Steam nozzles are of the convergent-divergent-type and re-boring will increase length of the throat and affect performance. The entrance should be re-rounded to reduce throat length to about one-quarter of its diameter.

- 3) Suction Chamber** – Normally suction chambers do not cause problems. The suction chamber should be cleaned out and inspected for structural integrity. If it is a casting, look for cracks that would allow leakage of air. If it is fabricated, check for cracks in welds, which would also affect performance due to air leakage. A simple hydrostatic test at 15 PSIG will determine the condition of the suction chamber.

## QUICKCHECK® EJECTOR STEAM CHEST

Inspection and maintenance of ejector assemblies has traditionally required from **several hours to days**, depending upon size and location of the equipment. You must isolate equipment, disconnect motive & process piping, remove the ejector and then disassemble it. With Unique Systems' patented Quickcheck Steam Chest ***this is a thing of the past!***

The Quickcheck Steam Chest's user-friendly design permits inspection, maintenance and prompt return of an ejector to service, ***including replacement of the steam nozzle***, without disassembling the entire unit! It requires the effort of only one person with an ordinary socket wrench to remove the cap on the steam chest. Each new unit includes a precision-machined **Performance Gauge Rod™** which instantly checks the critical nozzle and diffuser bores ensuring proper stage operation. Best of all, this is completed within **MINUTES!!**

Our Quickcheck design can also be retrofit onto existing steam jet ejectors, including those by other manufacturers.

## INSPECTION OF CONDENSERS

Barometric (direct-contact) condensers seldom cause performance problems if they were originally designed correctly. The most common problem is wear or corrosion of internal baffles and the spray nozzle. Failure of these parts will reduce cooling effectiveness and thereby cause an overload on the following stage. The baffles can also be loosened from supports and fall into positions where they impede or block the flow of water or vapors. The result will be flooding of the condenser with total loss of performance of the unit.

Another problem in barometric condensers occurs if the load contains material that will congeal when it comes in contact with the cold water in condenser. Plugging may occur in the condenser or in the tail pipe with subsequent failure of the unit to perform.

Where shell & tube heat exchangers are used as intercondensers, normal heat exchanger inspection and maintenance should be followed. Particular attention should be paid to restriction of vapor-side flow passages due to build-up of deposits, because resulting increased pressure drop will cause loss of performance of the ejector unit.

For both barometric and shell & tube condensers, a check should be made for integrity of shells against air leakage. Simply filling shells with water is generally sufficient to discover areas where air leakage is occurring.

### **The Unique "VIP" Service Advantage**

- Value, Integrity, Professionalism & Service •



# INSTALLATION, OPERATION, MAINTENANCE & TROUBLESHOOTING OF EJECTOR SYSTEMS

BULLETIN # PVS-80025121-ESM

PAGE 16 OF 18

## SYSTEM PROBLEMS

If testing of the ejector has shown that it is operating as designed, the system should be investigated to find the source of the problem.

The first step should be to determine air leakage into the system and compare this with design. The simplest way to determine air leakage is to operate the last stage ejector alone and use the performance curve for this stage to measure any air leakage. A performance curve for the last stage can be obtained from the ejector manufacturer at a nominal fee. Measuring the suction pressure of this stage with an accurate vacuum gauge will permit air leakage to be directly read from the curve.

An alternative method of checking air leakage is the "drop test." The ejector evacuates the system to a pressure as far below one-half of the existing barometric pressure as practical. The system is then isolated from the ejector and the ejector shut down. The rise in pressure of the system is timed, and the following formula used to determine leakage:

$$\text{Leakage (\#/Hour)} = \frac{0.15 \times V \times PR}{T}$$

**V** : System Volume (Cubic Feet)  
**PR** : Pressure Rise (Inches Hg)  
**T** : Time for PR (Minutes)

The following precautions should be observed for the drop test:

1. Pressure rise should be measured when system pressure is less than 0.53 times the barometric pressure.
2. System should be empty and free of liquid prior to test.
3. Moving equipment, such as mixers, should be operating to duplicate air leakage through glands and seals.

## PREVENTATIVE MAINTENANCE

The greatest contributor to ejector failure is poor steam. Wet steam causes erosion of nozzles & diffusers and accelerates erosion by removing protective scales from surfaces subject to corrosion.

The best solution for steam erosion is to furnish superheated steam to the ejector. If the steam supply is superheated as it leaves the boiler, good practice for insulating and trapping of steam lines to the ejector is necessary. To further insure superheated steam, the steam branch to the ejector should be taken off at a point between the boiler and another large steam-user. The worst possible arrangement is to run steam to the ejector from the end of a long run.

If the steam is not superheated at the boiler, or if the superheat in the steam is lost in long runs of piping, a steam separator should be installed and lines thoroughly trapped. The ejector should be served by its own steam separator, which has been sized correctly for the actual steam flow to the ejector. If stages are installed some distance from each other, there should be a separator for each stage or for each group of closely spaced stages. Stages with low steam consumption should have the steam line taken off between the separator and other stages with greater steam consumption, and the run should be kept as short as possible. **Figure 1** on Page 3 shows a typical ejector installation with a well-designed steam piping arrangement.

### The Unique "VIP" Service Advantage

- Value, Integrity, Professionalism & Service •





# INSTALLATION, OPERATION, MAINTENANCE & TROUBLESHOOTING OF EJECTOR SYSTEMS

BULLETIN # PVS-80025121-ESM

PAGE 17 OF 18

## CORROSION

If corrosion is a problem in the ejector unit, the best solution may be a change in materials. Ejector parts are available in a wide variety of materials including, but not limited to:

- |             |                |                   |               |
|-------------|----------------|-------------------|---------------|
| ✚ Cast Iron | ✚ Carbon Steel | ✚ Stainless Steel | ✚ Alloy Steel |
|             | ✚ Graphite     | ✚ Hasteg          |               |

## MAINTENANCE OF CONDENSERS

Routine maintenance on barometric condensers should include the removal of any materials that may have congealed in the condenser or which may have plugged the condenser tail pipe.

The most important maintenance on shell & tube intercondensers is periodic cleaning of vapor and water passages. Dirty condensers will cause a reduction in capacity of the system and eventually lead to unstable operation.

A hydrostatic test should be conducted to check for any leaks that may have resulted from the cleaning procedure.

## ENERGY SAVINGS

There are many opportunities for energy savings on ejector systems. This is particularly true of the older systems. The following are a few areas that should be considered:

- 1. Excessive Steam Pressure** – Many ejectors are operated with steam pressure far above minimum values established by the design pressure. The result is excessive and wasteful steam consumption. In addition, stage capacities are reduced by the higher pressure so that not only is steam wasted but capacity is reduced at the same time. The rationale for using the higher pressure is variously stated as wanting to avoid the maintenance on a pressure reducing station; to avoid loss of vacuum by inadvertent lowering of steam pressure; or, simply the mistaken notion that the higher pressure gives better performance.

Alternatives for improving energy efficiency when higher-than-design steam pressures are being used include:

- A) A pressure station set to provide steam at the minimum design value.
- B) Re-nozzle all stages for higher pressure.
- C) Re-nozzle all but the last stage for the higher pressure and re-nozzle last stage for minimum pressure that may only occur infrequently for short periods of time.

- 2. Replacing Inefficient Ejector Configurations** – When energy was low in cost, the choice of the number of stages and configurations was usually dictated primarily by cost. Higher equipment cost utilizing more efficient arrangements was not considered. The ejector manufacturer should be consulted for the following situations:

- A) The addition of an intercondenser on two- & three-stage non-condensing units will result in significant steam savings.
- B) Where single-stage units are designed for less than 120 Torr, two-stage units designed for less than 25 Torr and three-stage units designed for less than 6 Torr, steam savings are possible if a greater number of stages are used.

### **The Unique "VIP" Service Advantage**

- Value, Integrity, Professionalism & Service •



# INSTALLATION, OPERATION, MAINTENANCE & TROUBLESHOOTING OF EJECTOR SYSTEMS

BULLETIN # PVS-80025121-ESM

PAGE 18 OF 18

- 3) **Replacing Ejector Stages with Mechanical Vacuum Pumps** – A hybrid system, using a combination of ejector stages and pumps, can often show an improvement in energy utilization. The ejector manufacturer should be consulted on changes as they have the necessary knowledge of ejector characteristics to provide an optimum design.
- 4) **Using summer versus winter steam nozzles to take advantage of cooler water.**
- 5) **Using parallel 50% or 33% stages designed to take advantage of reduced capacity needs when operating processes at reduced rates.**
- 6) **Eliminating large factors of safety originally built into the equipment when energy costs were low.**

## WEAR IN DIFFUSERS IS MORE CRITICAL THAN INTERNAL WEAR IN NOZZLES

Wear in a nozzle tends to compensate for wear in a diffuser. In case of doubt as to the effects of wear, order a new diffuser first. A new diffuser will operate with a slightly worn nozzle while the effect of replacing a worn nozzle with a new one is to make operation worse if the diffuser is worn. You can operate with a worn nozzle and a new diffuser, but not with a new nozzle and a worn diffuser.

Always replace a worn diffuser with a new one. Experience shows that attempted repairs to worn diffusers are unsatisfactory. Both dimensions and proportions of diffusers are critical, so that for the attempted repair to have any chance of being satisfactory, it is necessary to enlarge the inside of the old diffuser enough to permit the installation of a liner, which must be accurately machined inside and outside. This rather large amount of very close tolerance machine work makes the attempted repair more expensive than a new diffuser.

## SUMMARY

Maintenance of ejector systems is a relatively simple task. It will more than pay for itself in the long-term thru trouble-free operation. By using the procedures outlined, and working closely with the ejector manufacturer, users can insure optimum performance of ejector vacuum systems.

**For high-quality replacement parts & assemblies, please contact Unique Systems at (973) 455-0440 or visit our website, [www.uniquesystems.com](http://www.uniquesystems.com), and refer to Spare Parts Bulletin # PVS-80021001-RSP.**

**NOTICE OF PROPRIETARY RIGHTS:** This brochure, drawings and/or information shown, is the sole property of Unique Systems, Inc. Receipt or possession thereof does not confer of transfer any right to make, copy, manufacture and/or sell this or these devices by method shown.

The information contained in this document is subject to change at any time and without prior notice. No warranties or guarantees of any kind are made or implied by any of the content of this document.

QUICKCHECK, UNIQUE SYSTEMS and its logo are registered trademarks of Unique Systems, Inc. Elliott is a registered trademark of the Elliott Turbomachinery Co.

© 2009 Unique Systems, Inc.

**The Unique "VIP" Service Advantage**

- Value, Integrity, Professionalism & Service •